

LED Waterproof Power Supply(C&V)

- Protections: short circuit/over load/over voltage/over temperature
- IP67 design for indoor or outdoor installation
- It can be used in dry, wet and rainy environment
- Cooling by free air, high reliability
- 100% full load burn-in test
- Suitable for internal lights application for I / II / III.
- Widely used in LED lighting and IT equipment
- Compliance to worldwide safety regulation for led lightings.



CE SELV IP67



Specification

Model	YSD-500WHB-12	YSD-500WHB-24	
OUTPUT	Output voltage	12VDC	24VDC
	Output voltage range	12VDC±0.5VDC	24VDC±0.5VDC
	Output current	Max 41.7A	Max 20.8A
	Output power	Max 500W	
	Output power range	0~500W	
	Ripple & Noise	≤120mV	≤240mV
	Linear Regulation	±1%	
	Load Regulation	±1%	
	Start-up Time (Typ)	450ms/230VAC 500ms/115VAC	
	Hold Up Time(Typ)	200ms/230VAC 200ms/115VAC	
INPUT	Input voltage	175-264Vac or 100-130Vac	
	Frequency	50/60Hz	
	Input current	4.2A/230Vac or 7.5A/115Vac	
	Power factor	PF>0.6	
	No-load power consumption	< 3W	
	Efficiency (typ.)	91%	90%
	Inrush current(typ.)	Cold start 70A at 230Vac	
	Control surge capability	L,N:2KV L,N-PE:4KV	
	Leakage current	Max. 0.5mA	
ENVIRONMENT	Working temperature	ta: -30°C~ 50°C tc: 80°C	
	Working humidity	20 ~ 99%RH, condensing(Waterproof)	
	Storage temp., humidity	-40°C ~ 80°C, 10~95%RH	
PROTECTION	Overtemperature	Protection type: Turn off the output voltage, after the temperature drops, re-energize to restore.	
	Over load protection	Shut down the output when current load ≥110%~150%, auto recovers.	
	Short circuit protection	Protection type: It can be automatically restored after the fault is eliminated.	
SAFETY & EMC	Withstand voltage	I/P-O/P:3750Vac	
	Isolation resistance	I/P-O/P: 100MΩ/500VDC/25°C/70%RH	
	Safety standards	IEC/EN61347;IEC/EN60950;IP67	
	EMC Test Standards	EN55015: 2013;EN61547: 2009; EN61000-3-2:2014; EN61000-3-3:2013	
Reliability and Quality Control	Impact aging	100% of the product is fully loaded and impacted for 4 hours under an environment of at least 40°C±5°C	
	Component derating	Under the steady-state conditions of rated input and output, the stress of components will not exceed its maximum nominal value	
NOTE	1. All parameters not specifically mentioned are measured at 230VAC input, rated load and 25°C ambient temperature. 2. Ripple and noise test method: connect 0.1uF and 47uF capacitors in parallel at the terminal, and measure under 20MHZ bandwidth. 3. Ensure that the power supply is used under the rated parameters and environment.		

Dimensions Unit:mm

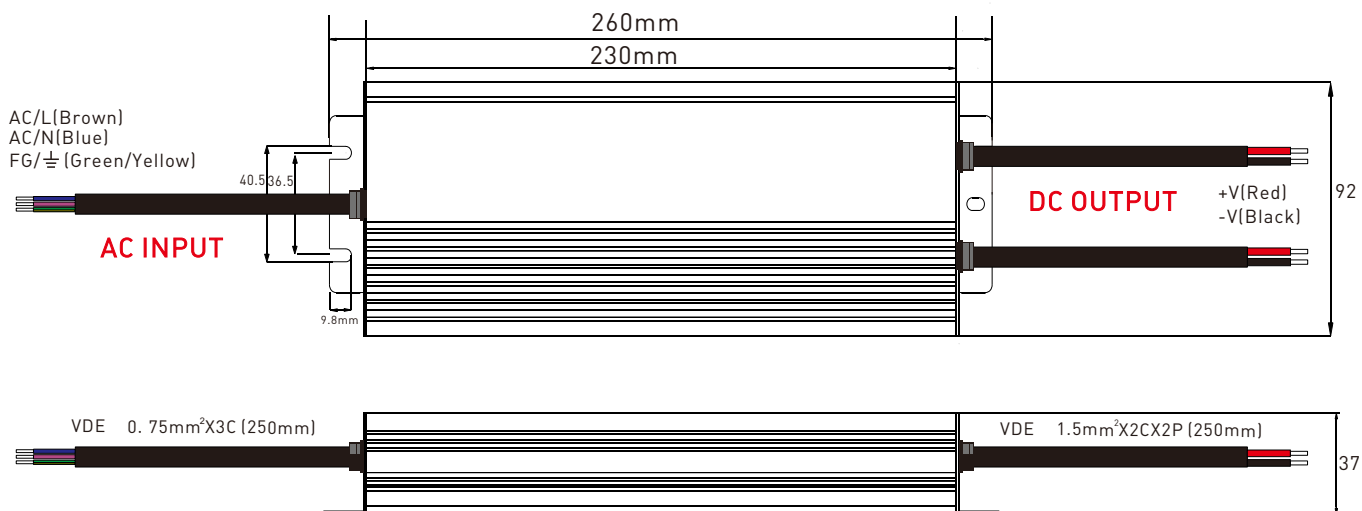

Relationship diagrams

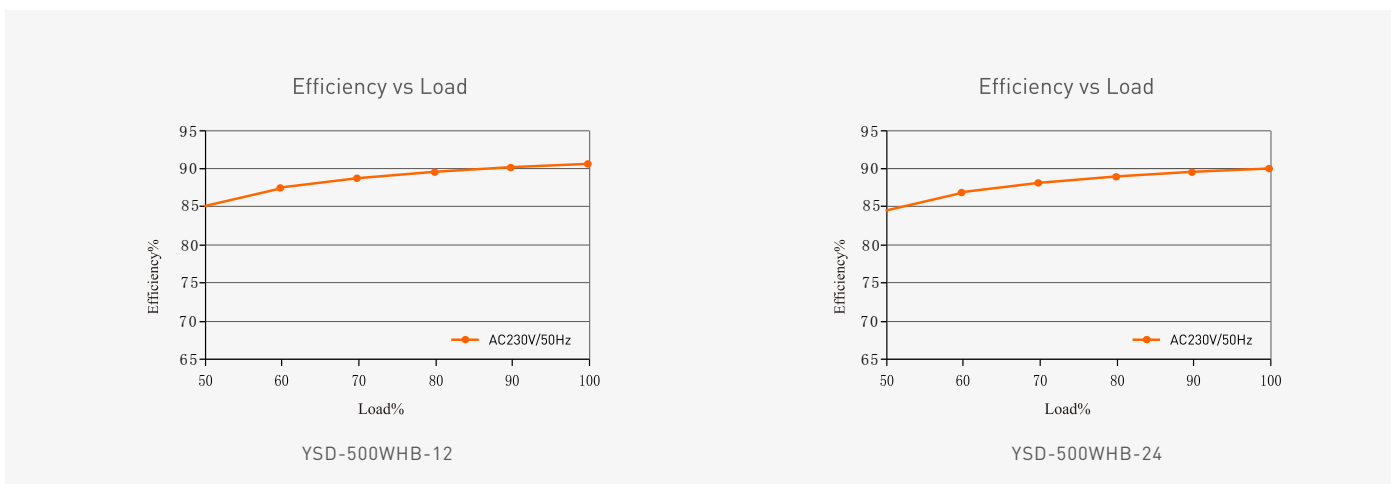

Packaging Information

DIMENSION	260x92x37mm(LxWxH)
PACKING	335x122x52mm(LxWxH)
CARTON QUANTITY	10PCS
CARTON SIZE	565x350x145mm(LxWxH)
WEIGHT	1750g±10g/PCS

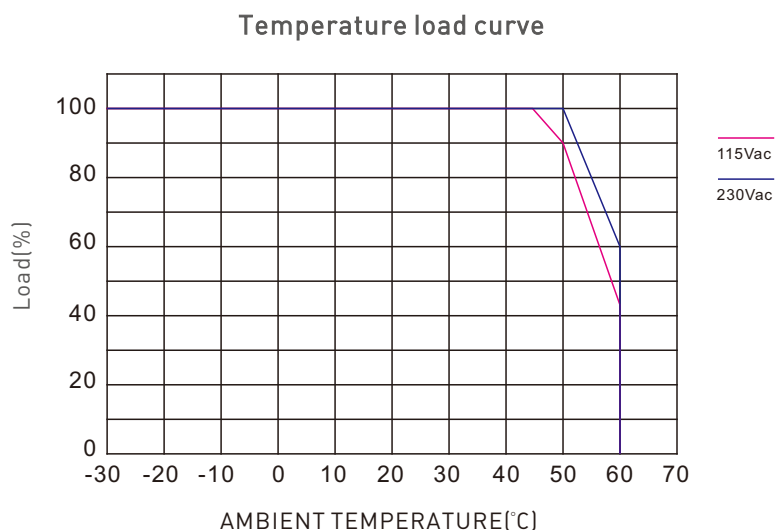

LED 防水电源(恒压型)

- 多重保护电路：短路、过电流、过电压、过温度
- IP67防水等级，室内室外均可安装
- 可用于干燥、潮湿、淋雨等环境下
- 自然风冷
- 100%满负荷老化测试
- 适合室内 I / II / III 类灯具使用，
- 广泛应用于LED照明类设备、IT类设备等
- 符合世界照明设备安全规范



CE SELV IP67



技术参数

型号	YSD-500WHB-12	YSD-500WHB-24	
输出	输出电压	12VDC	24VDC
	输出电压范围	12VDC±0.5VDC	24VDC±0.5VDC
	输出电流	Max 41.7A	Max 20.8A
	输出功率	Max 500W	
	输出功率范围	0~500W	
	纹波和噪音	≤120mV	≤240mV
	线性调整率	±1%	
	负载调整率	±1%	
	启动时间	450ms/230VAC 500ms/115VAC	
	保持时间	200ms/230VAC 200ms/115VAC	
输入	输入电压	175-264Vac or 100-130Vac	
	频率范围	50/60Hz	
	输入电流	4.2A/230Vac or 7.5A/115Vac	
	功率因素	PF>0.6	
	空载功耗	<3W	
	效率[typ.]	91%	90%
	浪涌电流[typ.]	冷启动 70A at 230Vac	
	抗浪涌	L,N:2KV L,N-PE:4KV	
	漏电流	Max. 0.5mA	
环境	工作温度	ta: -30°C~50°C tc: 80°C	
	工作湿度	20~99%RH, 冷凝(防水)	
	储存温度 湿度	-40°C~80°C, 10~95%RH	
保护	过温保护	保护类型: 关闭输出电压, 温度下降后, 重新通电恢复.	
	过载保护	负载电流 ≥110%~150%, 关闭输出, 可自动恢复.	
	短路保护	保护类型: 故障消除后可自动恢复.	
安规和电磁规格	耐压	输入对输出: 3750Vac	
	绝缘阻抗	输入对输出: 100MΩ/500VDC/25°C/70%RH	
	安全规范	IEC/EN61347; IEC/EN60950; IP67	
	EMC测试标准	EN55015: 2013; EN61547: 2009; EN61000-3-2: 2014; EN61000-3-3: 2013	
可靠性与质量控制	冲击式老化	产品100%在至少40°C ±5°C的环境下满载冲击式老化4小时.	
	元器件降额	在额定输入输出稳态条件下, 元器件的应力不会超过其最大标称值.	
备注	1. 所有未特别提及的参数均在230VAC输入, 额定负载和25°C环境温度下测量. 2. 纹波和噪声测试方法: 在终端并联0.1uF和47uF的电容, 并在20MHZ带宽下进行测量. 3. 保证电源在额定的参数和环境下使用.		

尺寸图

单位:mm

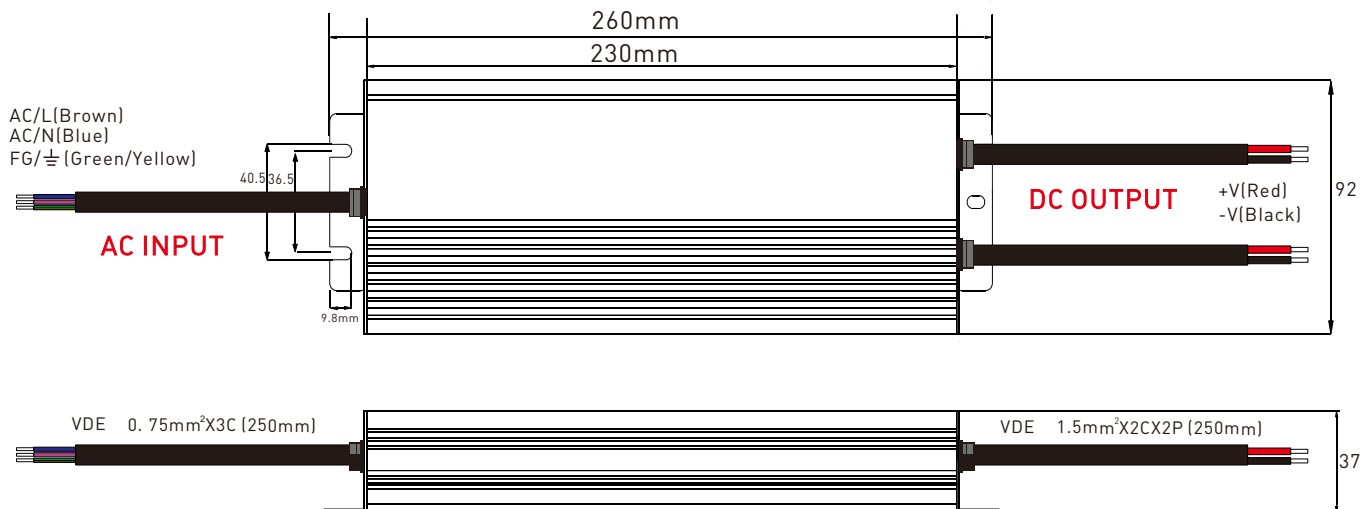

关系图表

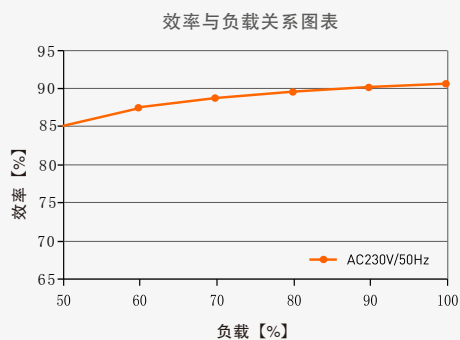

YSD-500WHB-12

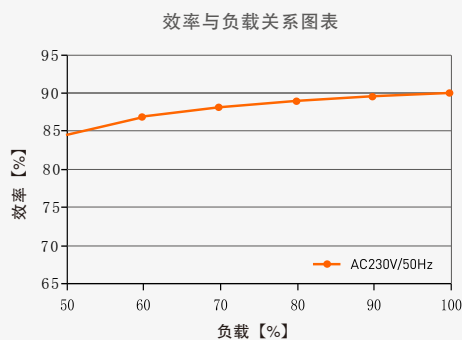

YSD-500WHB-24

温度负载曲线

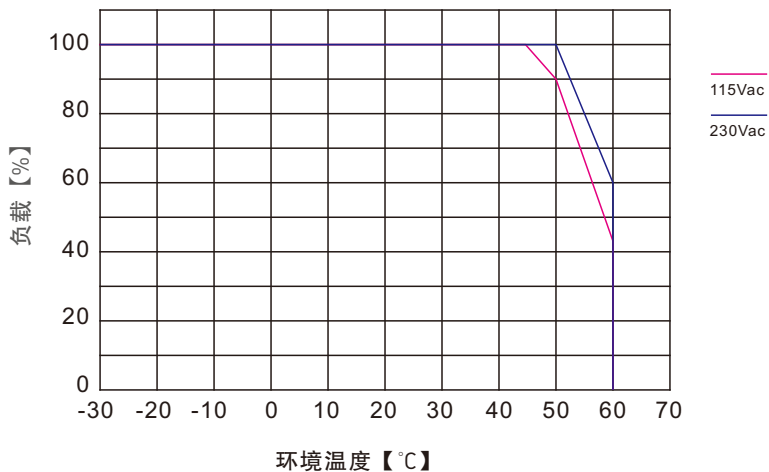

包装信息

产品尺寸	260x92x37mm(LxWxH)
包装尺寸	335x122x52mm(LxWxH)
装箱数量	10PCS
外箱尺寸	565x350x145mm(LxWxH)
产品重量	1750g±10g/PCS